

SU ELECTRIC FUEL PUMPS

SINGLE TYPE AUF 200/AZX 1200
 AUF 300/AZX 1300
(including L and HP Supplement)

DESCRIPTION, INSTALLATION & SERVICING INSTRUCTIONS



SU BUTEC

DORMER ROAD, THAME, OXFORD OX9 3UB
TELEPHONE 084-421 4511

SINGLE PUMP FEATURES

Type AUF 200/AZX1200

The versatile AUF 200/AZX1200 is the smaller of the current range of SU electric fuel pumps. A compact unit of high pressure design, it incorporates inlet and outlet connections adjustable through 210° to facilitate installation. A venting system allows the pump to be fully sealed.

Normally produced in 12-volt form, it is also available in 6-volt and 24-volt versions and a low pressure version is also produced.

The size and capacity of this pump makes it eminently suitable for use on vehicles in the low and middle power range.

Special features

- Freedom of installation:
 - Compact dimensions
 - Self-contained unit
 - Adjustable connections
 - Venting system available
- Rapid priming of float-chamber
- Excellent vapour handling capacity
- Twin tungsten contact breaker points.

Type AUF 300/AZX1300

The AUF 300/AZX1300 is a high capacity adaptation of the 200/1200, the pump body having been redesigned to incorporate a flow-smoothing unit and an air bottle.

The flow-smoothing unit consists of a diaphragm and housing situated above the delivery chamber and outlet passage. Fuel pressure pulsations are damped by the air contained in the housing, resulting in a reduction of flow pressure variations and an increase in output for a given rate of operation.

A large compartment formed in the inlet side of the pump acts as an air cushion and smoothes the pressure pulsations of the incoming fuel; it also prevents high negative pressure being created in the pump body.

Special features

The features are similar to those of the type AUF 200/AZX1200 pump plus

- High output
- Flow-smoothing on inlet and outlet.



Plate A

The SU Type AUF 200/AZX1200 Pump

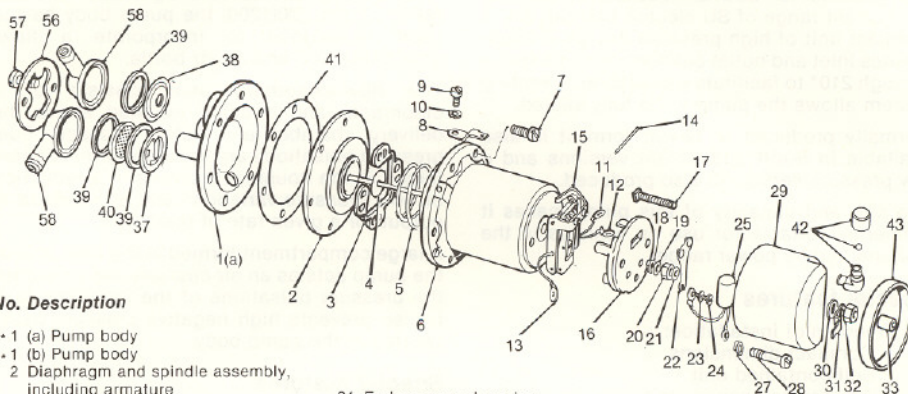

No. Description

- 1 (a) Pump body
- 1 (b) Pump body
- 2 Diaphragm and spindle assembly, including armature
- 3 Armature centralizing plate
- 4 Impact washer
- 5 Armature spring
- 6 Coil housing
- 7 Screw, securing housing, 2 BA
- 8 Earth connector
- 9 Screw, 4 BA
- 10 Spring washer, 4 BA
- 11 Terminal tag, 5 BA
- 12 Terminal tag, 2 BA
- 13 Earth tag, 2 BA
- 14 Rocker pivot pin
- 15 Rocker mechanism
- 16 Pedestal
- 17 Terminal stud
- 18 Spring washer
- 19 Lead washer
- 20 Terminal nut
- 21 End cover seal washer
- 22 Contact blade
- 23 Washer, 5 BA
- 24 Contact blade screw, 5 BA
- 25 Diode resistor (optional)
- 26
- 27 Spring washer, 2 BA
- 28 Screw, pedestal to housing, 2 BA
- 29 End cover
- 30 Shakeproof washer
- 31 Lucar connector
- 32 Nut, 2 BA
- 33 Insulating sleeve
- * 34 Clamp plate
- * 35 Plate screw
- * 36 Valve cap
- 37 Inlet valve
- 38 Outlet valve
- 39 Sealing washer
- 40 Filter
- 41 Diaphragm gasket
- 42 Vent valve
- 43 Sealing band
- + 44 Joint, inlet air bottle cover
- + 45 Cover, inlet air bottle
- + 46 Dished washer
- + 47 Spring washer
- + 48 Screw, securing cover
- + 49 Outlet connection
- + 50 Fibre washer/O' ring
- + 51 Cover, delivery flow smoothing device
- + 52 Screw, securing cover
- + 53 Rubber 'O' ring
- + 54 Plastic diaphragm barrier
- + 55 Sealing washer
- ** 56 Plate clamp
- ** 57 Securing screw, 2 BA
- ** 58 Inlet and outlet nozzle
- + 59 Fuel inlet

Items marked ** refer to AUF200 & AZX1200 types only
 Items marked + refer to AUF300 & AZX1300 types only

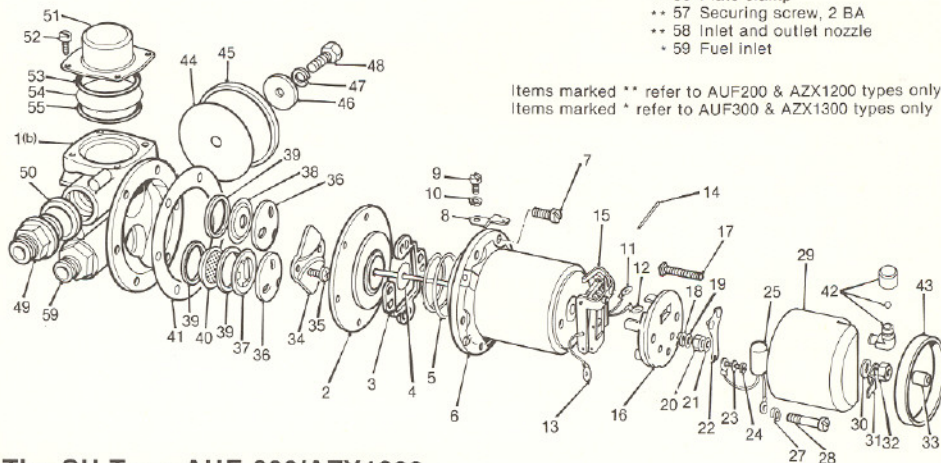

The SU Type AUF 300/AZX1300 Pump

Plate B

DESCRIPTION AND OPERATION

Description

The pump comprises three main assemblies: the body casting, the diaphragm, armature and magnet assembly, and the contact breaker assembly.

The body (AUF 200/AZX1200 only)

(Refer to illustration, Plate A)

The body (1) is a casting into which the clamp plate (56), retained by two screws (57), holds the inlet and outlet moulded nozzles (58) and both valve assemblies, all of which are arranged to be accessible from the outside of the pump. The inlet valve (37) consists of a thin plastic disc permanently assembled into a pressed steel cage. The outlet valve (38) is an identical assembly, but reversed in direction. A dome-shaped filter (40) is provided on the entry side of the inlet valve. The valve allows passage to the pumping chamber – a shallow depression formed in the face of the body casting and bounded by the diaphragm.

The body (AUF 300/AZX1300 only)

(Refer to illustration Plate B)

The main fuel inlet (59) is in communication with an inlet air bottle (flow-smoother), and connection to the main pumping chamber is provided by the inlet valve assembly (37). This comprises a plastic valve disc permanently assembled within a pressed-steel cage, which is held in place by a valve cover (36). The outlet from the pumping chamber is provided with an identical valve assembly (38) reversed in direction. A clamp plate (34) secured by self-tapping screws (35) holds both inlet and outlet valve assemblies in position: the valves may be removed by releasing the clamp plate screws. A filter (40) is provided as shown – on the entry side of the inlet valve assembly.

The outlet flow-smoothing device is fitted across the extremity of the delivery chamber which communicates with the outlet union (49). The outlet smoothing device assembly consists of a flexible plastic diaphragm (54) contained between the domed cover and the outlet chamber.

The inlet valve (37) allows passage to the pumping chamber which is formed by a shallow depression in the body casting and bounded by the diaphragm (2).

The diaphragm, armature and magnet assembly

The diaphragm (2) is clamped at its outer edge between the coil housing (6) and the body, and attached at its centre to the iron armature. The

armature spindle passes freely through the magnet core, and is screwed into a trunnion carried by the inner rocker (15). A plastic armature guide plate (3) centralises the armature and allows freedom of movement in a longitudinal direction. An atmospheric vent may be fitted to the coil housing.

The contact breaker assembly

This assembly consists of a bakelite pedestal moulding (16) which carries two rockers, outer and inner (15) both hinged to the moulding at one end by the rocker spindle and interconnected at their top ends by two small toggle springs arranged to give a 'throw over' action. The inner rocker, as mentioned, carries a trunnion into which the armature spindle is screwed. The outer rocker is fitted with one or two tungsten points which contact other tungsten points carried by the spring blade (22). One end of the coil (6) is connected electrically to the spring blade and the other end is connected to the terminal stud (17). A short length of flexible wire (13) connects the outer rocker to one of the screws securing the pedestal moulding to the coil housing, thus providing an earth return, this wire must then be thoroughly earthed to the body or chassis of the vehicle via the earthing screw (9). A non-return valve (42) may be fitted to the end-cover moulding (29) to aid the circulation of air through the contact-breaker chamber. A diode-resistor (25), where fitted, is in parallel with the points as a spark suppressor to increase the life of the points. Some earlier models were fitted with a condenser rather than a diode resistor.

Operation of the pump

When the pump is at rest, the outer rocker lies so that the tungsten points make contact. When switched on, current passes from the terminal stud (17) through the coil, back to the spring blade (22) through the points and so to earth, thus energizing the coil and attracting the armature (2). The armature, together with the diaphragm assembly moves towards the coil, against pressure from the armature spring (5), drawing fuel through the inlet valve into the pumping chamber. When the armature has travelled well towards the end of its stroke the 'throw over' mechanism operates and the outer rocker moves rapidly backwards, thus separating the contact points and breaking the circuit. The armature and diaphragm will now move away from the coil under the influence of the armature spring, thereby expelling the fuel through the outlet valve at a rate determined by the requirements of the engine. As the armature approaches the end of its stroke, away from the coil, the 'throw over' mechanism again operates, the tungsten points re-make contact, and the cycle of operations is repeated.



AUF200/AZX1200 INSTALLATION & PERFORMANCE DATA

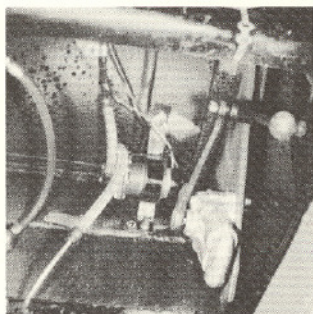
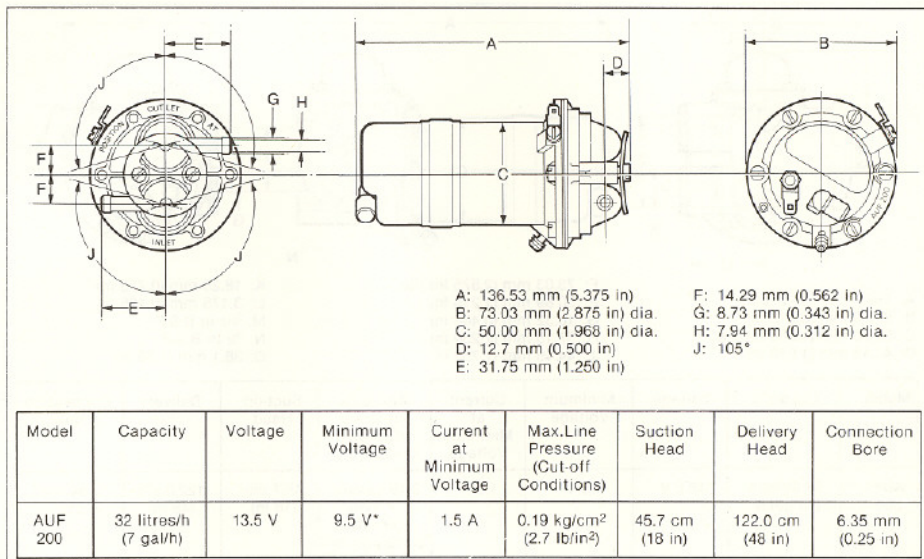

*9.5 V is the minimum starting voltage for pumps with standard coils. Some pump specifications use alternative coils which offer reduced minimum starting voltage.

Typical installation of type AUF200/AZX1200 pump

Where pumps with vents are used, the vent should be piped to a region of dry air, e.g. car interior or luggage compartment.

TYPE AUF200/AZX1200 PUMP

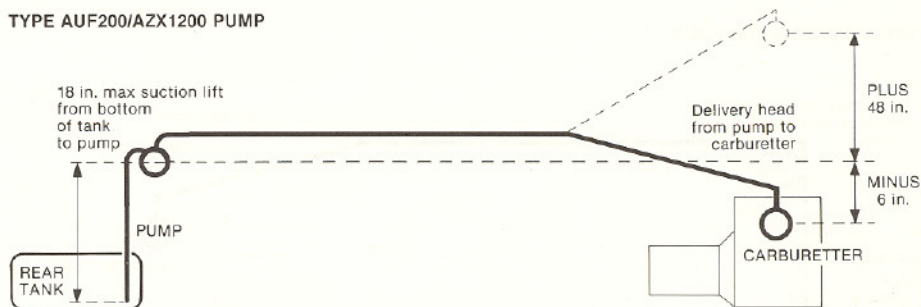

AUF300/AZX1300 INSTALLATION & PERFORMANCE DATA

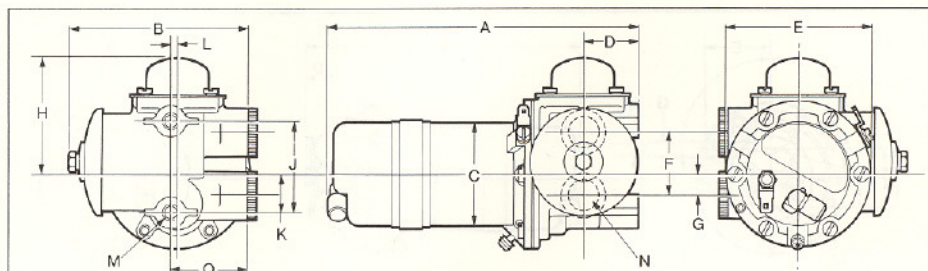

A: 157.74 mm (6.210 in)
 B: 89.29 mm (3.515 in)
 C: 50.00 mm (1.968 in) dia.
 D: 43.18 mm (1.070 in)

E: 73.03 mm (2.875 in) dia.
 F: 30.89 mm (1.216 in)
 G: 10.32 mm (0.406 in)
 H: 57.15 mm (2.250 in)
 J: 44.45 mm (1.750 in)

K: 18.25 mm (0.718 in)
 L: 3.175 mm (0.125 in)
 M: $\frac{7}{16}$ in B.S.F.
 N: $\frac{3}{8}$ in B.S.P.
 Q: 38.1 mm (1.50 in)

| Model | Capacity | Voltage | Minimum Voltage | Current at Minimum Voltage | Max. Line Pressure (Cut-off Conditions) | Suction Head | Delivery Head | Connection Bore |
|---------|------------------------|---------|-----------------|----------------------------|--|-----------------|------------------|--------------------|
| AUF 300 | 68 litres/h (15 gal/h) | 13.5 V | 9.5 V* | 1.5 A | 0.19 kg/cm ² (2.7 lb/in ²) alternative 0.262 kg/cm ² (3.8 lb/in ²) | 45.7 cm (18 in) | 122.0 cm (48 in) | 7.94 mm (0.312 in) |

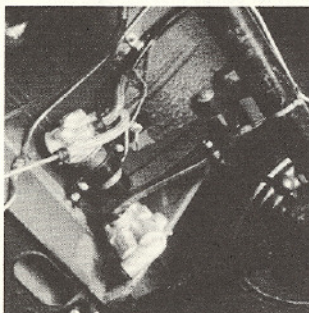

*9.5 V is the minimum starting voltage for pumps with standard coils. Some pump specifications use alternative coils which offer reduced minimum starting voltage.

Typical installation of type AUF300/AZX1300 pump

Where pumps with vents are used, the vent should be piped to a region of dry air, e.g. car interior or luggage compartment.

TYPE AUF300/AZX1300 PUMP

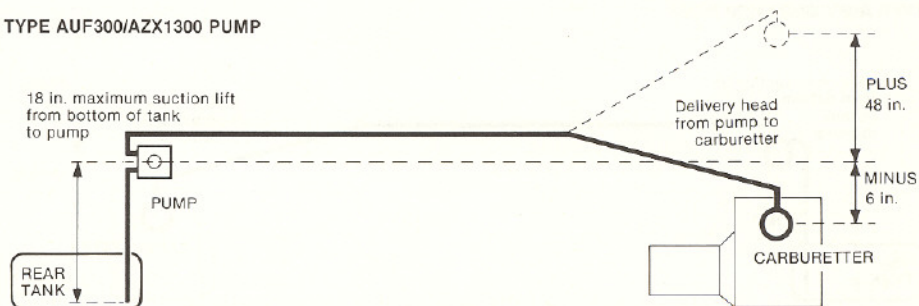

(AUF300 RANGE - 15 GALLONS PER HOUR AT 18 in. SUCTION HEAD)

A1185B

SERVICING AND FAULT DIAGNOSIS

Dismantling

Contact breaker

- 1 Remove the insulating sleeve (33), terminal nut (32) and connector (31), together with its shakeproof washer. Remove the tape seal (if fitted) and take off the end-cover.
- 2 Unscrew the 5 BA screw (24) which holds the contact blade (22) to the pedestal (16). This will allow the washer (23), the long coil lead (11), and the contact blade to be removed.

Coil housing and diaphragm

- 3 Unscrew coil housing securing screws (7), using a screwdriver with a well-fitting blade to avoid damaging the screw heads.
- 4 Remove the earthing screw (9).
- 5 The coil housing (6) may now be removed from the body (1). Next turn back the edge of the diaphragm assembly (2) and remove the armature guide plate (3) from the coil recess (see Fig. 1).

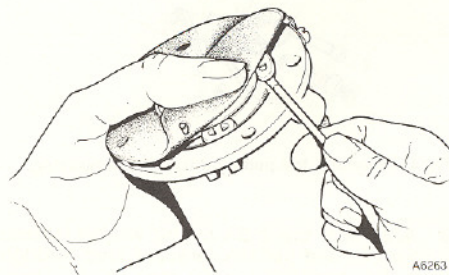

Fig 1. Gently probe the two end lobes of the armature guide plate free from the coil recess.

Now remove the diaphragm and spindle assembly (2) by taking hold of the diaphragm and unscrewing it anti-clockwise until the armature spring (5) pushes the diaphragm away from the coil housing.

Pedestal and rocker

- 6 Remove the end-cover seal washer (21), unscrew the terminal nut (20), and remove the lead washer (19); this will have flattened on the terminal tag and thread and is best cut away with cutting pliers or a knife. Unscrew the two 2 BA screws (28), holding the pedestal to the coil housing and remove the earth terminal tag (13). Tip the pedestal and withdraw the terminal stud (17) from the terminal tag (12). The pedestal (16) may

now be removed with the rocker mechanism (15) attached.

- 7 Push out the hardened steel pin (14) which holds the rocker mechanism to the pedestal and separate the two parts.

Body and valves

- 8 (a) (Type AUF 200/AZX1200 only). Unscrew the two 2BA screws (57) securing the spring clamp plate (56) which holds the inlet and outlet nozzles (58). Remove the nozzles, filter (40), and valve assemblies (37) and (38).
- 8 (b) (Type AUF 300/AZX1300 only). Undo the two screws (35) securing the valve clamp plate (34), remove the valve caps (36), valves (37) and (38), sealing washers and the filter (40).

Note: Dismantling of the delivery flow-smoothing device should only be undertaken if the operation of it is faulty, and if the necessary equipment for pressure-testing after assembly is available. On this understanding proceed as follows:

Remove the four 4 BA screws (52) securing the delivery flow-smoothing device cover (51), remove the cover, rubber 'O' ring (53), barrier (54), and sealing washer (55).

Remove the single 2 BA screw (48) securing the inlet air bottle cover (45). Remove the cover and gasket (44), then unscrew the inlet and outlet connections.

Inspection

If gum formation has occurred in the fuel used in the pump, the parts in contact with the fuel will have become coated with a substance similar to varnish. This has a strong stale smell and may attack the neoprene diaphragm. Parts so affected may be cleaned by the use of a suitable solvent.

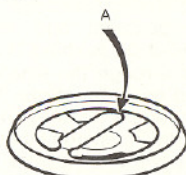

Fig. 2. The valve (inlet and outlet). A = 1.6 mm ($\frac{1}{16}$ in)

- 1 Clean the pump and inspect for cracks, damaged joint faces and threads.
- 2 Examine the plastic valve assemblies (see Fig. 2) for kinks or damage to the valve plates. They can best be checked by blowing and sucking with the mouth.

- 3 Check that the narrow tongue on the valve cage (which is bent over to retain the valve and to prevent it being forced out of position), has not been distorted but allows a valve lift of approximately 1.6 mm ($\frac{1}{16}$ in).
- 4 Examine the valve recesses in the body for damage and corrosion; if it is impossible to remove the corrosion, or if the seat is pitted, the body must be discarded.
- 5 Ensure that the coil housing vent tube is not blocked.
- 6 Clean the filter with a brush and examine for fractures, renew if necessary.
- 7 Examine the coil lead tag for security and the lead insulation for damage.
- 8 Examine the contact breaker points for signs of burning and pitting; if this is evident, the rocker assembly and spring blade must be renewed.
- 9 Examine the pedestal for cracks or other damage, particularly to the narrow ridge on the edge of the rectangular hole on which the contact blade rests.
- 10 Examine the non-return vent valve in the end-cover (if fitted) for damage. Ensure that the small ball valve is free to move.
- 11 Examine all diaphragms for any signs of deterioration.
- 12 Renew the following parts: All fibre and cork washers, gaskets, and 'O' section sealing rings, armature guide plate (if worn), damaged bolts and unions.

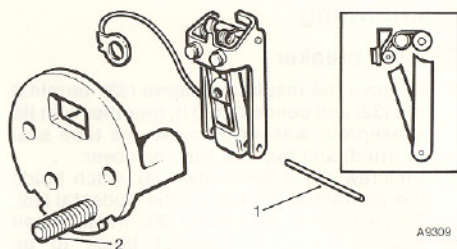

Fig 3. Fitting the rocker assembly to the pedestal. (Inset) the correct position of the centre toggle spring.

- 2 Assemble the square-headed 2 BA terminal stud (2) to the pedestal, the back of which is recessed to take the square head (see Fig. 3).

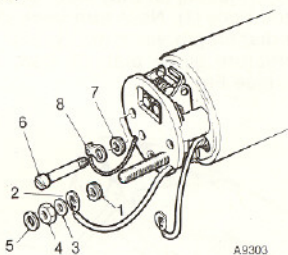

Fig 4. Attaching the pedestal to the coil housing.

- 3 Assemble the 2 BA spring washer (1) (see Fig. 4), and put the terminal stud through 2 BA terminal tag (2), then fit the lead washer (3) and the coned nut with its coned face to the lead washer. (This makes better contact than an ordinary flat washer and nut.) Tighten the 2 BA nut and finally add the end-cover seal washer (5).
- 4 Assemble the pedestal to the coil housing (see Fig. 4) by fitting the two 2 BA pedestal screws (6), and ensure that the spring washer (7) on the left-hand screw (9 o'clock position) is between the pedestal and the earthing tag (8).
- 5 Tighten the screws, taking care to prevent the earthing tag (8) from turning, as this will strain or break the earthing flex. Do not overtighten the screws or the pedestal will crack.

Do not fit the contact blade at this stage.

Assembly

Pedestal and rocker

Note: The steel pin which secures the rocker mechanism to the pedestal is specially hardened and must not be replaced by other than a genuine SU part.

- 1 Invert the pedestal and fit the rocker assembly to it by pushing the steel pin (1) (see Fig. 3) through the small holes in the rockers and pedestal struts. Then position the centre toggle so that, with the inner rocker spindle in tension against the rear of the contact point, the centre toggle spring is above the outer rocker spindle.

This positioning is important to obtain the correct 'throw-over' action; it is also essential that the rockers are perfectly free to swing on the pivot pin and that the arms are not binding on the legs of the pedestal.

If necessary the rockers can be squared up with a pair of thin-nosed pliers.

Diaphragm assembly

- 6 Place the armature spring into the coil housing with its large diameter towards the coil (see Fig. 5).
- 7 Before fitting the diaphragm, make sure that the impact washer is fitted to the armature. (This is a small neoprene washer that fits in the coil recess.) Do not use jointing compound or dope on the diaphragm.

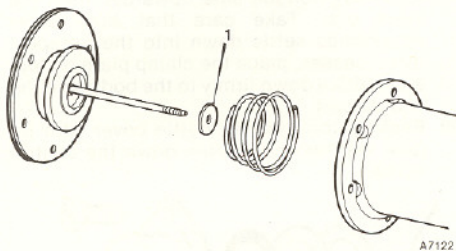

Fig. 5. Fitting the diaphragm to the coil housing. Note the impact washer (1).

- 8 Fit the diaphragm by inserting the spindle into the hole in the coil and screwing it into the threaded trunnion in the centre of the rocker assembly.
- 9 Screw in the diaphragm until the rocker will not 'throw over'; this must not be confused with jamming the armature on the coil housing integral steps.
- 10 On later-type rocker mechanisms with adjustable fingers, fit the contact blade and adjust the finger settings as described under those headings, then carefully remove the contact blade.
- 11 Holding the coil housing assembly in the left hand in an approximately horizontal position (see Fig. 6) push the diaphragm

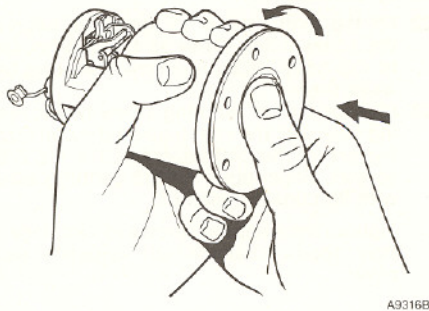

Fig. 6. Setting the diaphragm. Unscrew until the rocker just 'throws over'.

- spindle in with the thumb of the right hand, pushing firmly but steadily. Unscrew the diaphragm, pressing and releasing with the thumb of the right hand until the rocker just 'throws over'. Now turn the diaphragm back (unscrew) to the nearest hole and again a further four holes (two-thirds of a complete turn). The diaphragm is now correctly set.
- 12 Fit the armature guide plate, flat face towards the diaphragm, by turning back the diaphragm edge (see Fig. 7) and inserting an end lobe into the recess between the armature and the coil housing. Follow this process until all four lobes are approximately in position, then press each lobe firmly home finishing with the two end ones. The latter instruction is important in order to avoid distortion of the connecting arms between the lobes.

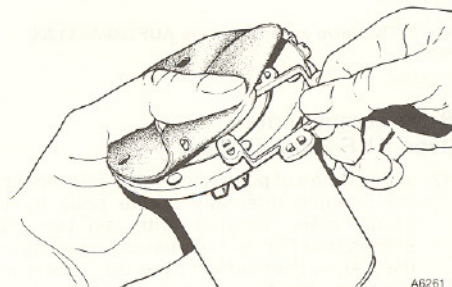

Fig. 7. Insert an end lobe into the recess between the armature and the coil housing, follow this process until all four lobes are approximately in position, then press each lobe firmly home, finishing with the two end ones.

Body components (type AUF 200/AZX1200)

- 13 In this range of pumps, the inlet and outlet valves are identical assemblies and are held in position in the one-piece body casting by a steel spring clamp plate secured by two 2 BA screws. This plate also secures the inlet and outlet nozzles, including the filter, all of which are arranged to be accessible from the outside of the pump (see Fig. 8). The inlet recess is deeper than the outlet to allow for the filter and extra washer.
- 14 Referring to Fig. 8, place the outlet valve assembly (tongue side uppermost) in the recess marked 'outlet', place a joint washer on top of the valve assembly, and complete this part of assembly by adding the outlet nozzle.
- 15 Place the inlet valve assembly (tongue side downwards) in the recess marked 'inlet', follow this with a joint washer, then the

filter (dome side upwards), then another joint washer, completing the assembly with the inlet nozzle.

- 16 Take care that both assemblies settle down evenly into their respective recesses. Position the nozzles as required, place the clamp plate on top, and tighten down firmly onto the body with the two 2 BA screws.

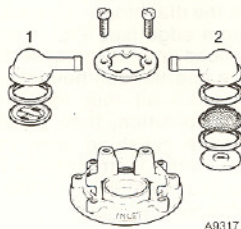

Fig 8. The valve assembly, type AUF200/AZX1200 pump.

1 Outlet 2 Inlet

Body components (type AUF 300/AZX1300)

- 17 In this range of pumps the valve assemblies are retained internally in the body by a clamp plate secured with self-tapping screws (see Fig. 9). The inlet valve recess in the body is deeper than the outlet recess to allow for the filter and the extra washer.

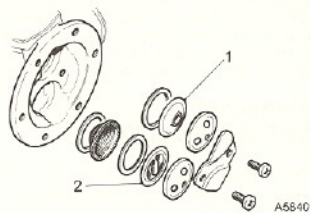

Fig 9. The valve assembly, type AUF300/AZX1300 pump.

1 Outlet valve 2 Inlet valve

Another feature of these pumps is the incorporation of an air bottle on the inlet and a flow-smoothing device on the delivery side.

The inlet air bottle is a chamber in the body casting blanked off by a simple cover and joint washer held in place by a single screw.

The delivery air bottle is formed by a flexible plastic diaphragm, separating the delivery chamber in the body from a sealed volume of air contained in the air bottle cover. This cover is secured by four screws and sealed by an 'O' section sealing ring and joint washer.

- 18 Screw in the inlet and outlet connections together with their sealing rings. Assemble the outlet valve components into the outlet recess in the following order: first a joint washer, and then the valve (tongue side downwards), then the valve cap.
- 19 Assemble the inlet valve into the inlet recess as follows: first a joint washer, then the filter (dome side downwards), then another joint washer, followed by the valve assembly (tongue side upwards), then the valve cap. Take care that both valve assemblies settle down into their respective recesses, place the clamp plate on top, and tighten down firmly to the body with the two screws.
- 20 Replace the inlet air bottle cover with its joint washer and tighten down the central screw.

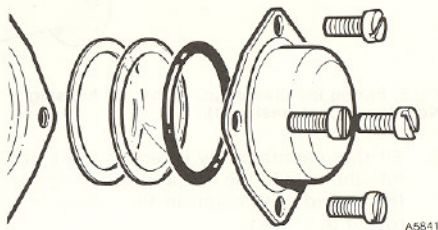

Fig 10. The delivery air bottle, type AUF300/AZX1300 pumps.

- 21 Place a sealing washer in the bottom of the delivery air bottle recess, place the plastic diaphragm (dome side downwards) then add the 'O' section sealing ring and tighten down the cap with its four screws (see Fig. 10).

The pump should be pressure-tested after disturbance of the delivery air bottle.

Body attachment

- 22 Fit the joint washer to the body, aligning the screw holes. Offer up the coil housing to the body, ensuring correct seating between them.
- 23 Line up the six securing screw holes, making sure that the cast lugs on the coil housing are at the bottom, insert the six 2 BA screws, finger-tight. Fit the earthing screw with its Lucar connector.

Tighten the securing screws in sequence as they appear diametrically opposite each other.

Contact blade

- 24 Fit the contact blade (2) Fig. 11) and coil lead (1) to the pedestal (3) with the 5 BA washer and screw. Where a diode resistor is fitted it is in parallel with the coil connections. This component is polarity conscious and therefore all connections must be correctly made. A condenser, where fitted, is not polarity conscious.

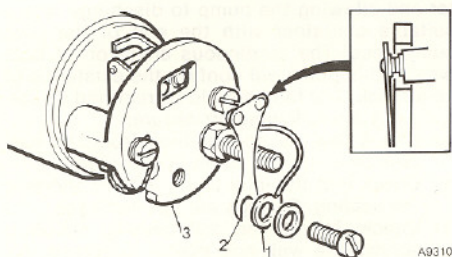

Fig 11. Setting the correct relative position of blade and rocker contact points.

- 25 Adjust the contact blade so that the contact points on it are a little above the contact points on the rocker when the points are closed (Fig. 11), also that when the contact points make or break, one pair of points wipes over the centre line of the other in a symmetrical manner. As the contact blade is provided with a slot for the attachment screw, some degree of adjustment is possible.
- 26 Tighten the contact blade attachment screw when the correct setting is obtained.

Contact gap setting

- 27 Check that when outer rocker is pressed on to the coil housing, the contact blade rests on the narrow rib or ridge which projects slightly above the main face of the pedestal (see Fig. 12). If it does not, slacken the con-

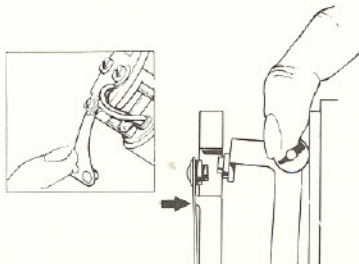

Fig 12. Setting the contact blade to ensure contact with the pedestal ridge.

tact blade attachment screw, swing the blade clear of the pedestal, and bend it downwards a sufficient amount so that when repositioned it rests against the rib lightly, over-tensioning of the blade will restrict the travel of the rocker mechanism.

- 28 Check the lift of the contact blade tip above the top of the pedestal (A) (Fig. 13) with a feeler gauge, bending the stop finger 'X' beneath the pedestal, if necessary, to obtain a lift of $0.9 \text{ mm} \pm 0.13 \text{ mm}$ ($0.035 \pm 0.005 \text{ in}$).
- 29 Check the gap between rocker finger and coil housing (B) (Fig. 13) with a feeler gauge, bending the stop-finger 'Y', if necessary, to obtain a gap of $2.3 \text{ mm} \pm 0.13 \text{ mm}$ ($0.090 \pm 0.005 \text{ in}$).

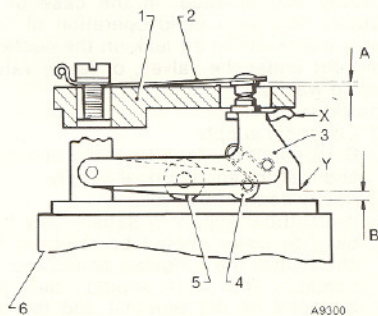

Fig 13. The rocker finger settings on modified rocker assemblies.

| | |
|-----------------|---|
| 1 Pedestal | 5 Trunnion |
| 2 Contact blade | 6 Coil housing |
| 3 Outer rocker | A = 0.9 mm (0.035 in) |
| 4 Inner rocker | B = 2.3 mm (0.090 in) |

End-cover

- 30 Tuck all spare cable into position so that it cannot foul the rocker mechanism. See that the diode resistor or condenser is fitted snugly into the end cover at the correct attitude. Ensure that the end-cover seal washer is in position on the terminal stud. Fit the bakelite end-cover and lock washer, secure with the brass nut, fit the terminal tag or connector, and then the insulated sleeve.
- 31 The pump is now ready for test. After test replace the rubber sealing band over the end cover gap and seal with adhesive tape. This may be removed to improve ventilation when the pump is mounted internally in a moisture-free region but must be retained otherwise.

FAULT DIAGNOSIS

1 Suspected fuel feed failure

Disconnect the fuel line at the carburetter and check for flow

- (a) If normal, examine the carburetter for obstructed float-chamber needle seating or gummed needle.
- (b) If normal initially, but diminishing rapidly and accompanied by slow pump operation, check for correct tank venting by removing the filler cap. Inadequate venting causes a slow power stroke, with resultant excessive burning of contact points.
- (c) If a reduced flow is accompanied by slow operation of the pump, check for any restriction on the inlet side of the pump, such as a clogged filter, which should be removed and cleaned. In the case of a reduced flow with rapid operation of the pump, check for an air leak on the suction side, dirt under the valves, or faulty valve sealing washers.
- (d) If no flow, check for:
 - (i) *Electrical supply*
Disconnect the lead from the terminal and test for an electrical supply.
 - (ii) *Faulty contact points*
If electrical supply is satisfactory the bakelite cover should be removed to check that the tungsten points are in contact. The lead should then be replaced on the terminal and the top contact blade connected briefly to a good earth. If the pump then performs a stroke the fault is due to dirt, corrosion or maladjustment of the tungsten points.
 - (iii) *Obstructed pipeline between fuel tank and pump*
The inlet pipe should be disconnected; if the pump then operates, trouble is due to a restriction in the pipeline between the pump and the tank. This may be cleared by the use of compressed air after removing the fuel tank filler cap. It should be noted, however, that compressed air should not be passed through the pump, as this will cause serious damage to the valves.
 - (iv) *Faulty diaphragm action*
If the previous operations fail to locate the trouble, stiffening of the diaphragm fabric or abnormal friction in the rocker throw-over mechanism is then to be suspected. To remedy these faults, the coil housing should be removed and the diaphragm flexed a few times. Prior to reassembly, it is advisable to apply a little thin oil to the throw-over spring spindles at a point where they pivot in the brass rockers. The diaphragm/

armature assembly should then be assembled and set in accordance with instructions given under that heading.

2 Noisy pump

Air leaks. If the pump is noisy in operation, an air leak at one or other of the suction lines may be the cause. Such a leak may be checked by disconnecting the fuel pipe from the carburetter and allowing the pump to discharge into a suitable container with the end of the pipe submerged. The continuous emission of bubbles at this point will confirm the existence of an air leak. The fault should be rectified by carrying out the following procedure:

- (a) Check that all connections from the fuel tank to the pump are in good order.
- (b) Check that the inlet union is tight and that the sealing 'O' rings are not damaged.
- (c) Check that all the coil housing securing screws are well and evenly tightened. Air leaks on the suction side cause rapid operation of the pump and are the most frequent cause of premature failure.

3 Pump operates without delivering fuel

If the pump operates without delivering fuel the most likely causes are:

- (a) A serious air leak on the suction side, or,
- (b) foreign matter lodged under one of the valves, particularly under the inlet valve.

To remedy (a) see para 2 above.

To remove any foreign matter lodged under the valves these should be removed for cleaning, care being taken that the Melinex material of the valve disc is not scratched or damaged during this operation.

The technical information contained in this Service brochure supersedes any previous instructions published or authorized on this subject by the Company.